

- L:
- CBL-USPD302MB-0.5mLA 500mm±10mm
  - CBL-USPD302MB-1mLA 1000mm±10mm
  - CBL-USPD302MB-2mLA 2000mm±20mm
  - CBL-USPD302MB-3mLA 3000mm±20mm

No	MATERIALS LIST:
1.	CABLE:UL2725 (32AWG*1PR+D+AM)x2C+32AWG*1PR+24AWG*1C+AM+B OD:4.2mm PVC JACKET COLOR:BLUE
2.	CONNECTOR:USB 3.0 A/M, 9P, BLUE INSULATOR SOLDER TYPE, NICKEL PLATED SHELL
3.	CONNECTOR:USB 3.0 MicroB/M, 10P, BLACK INSULATOR SOLDER TYPE, NICKEL PLATED SHELL
4.	PVC MOLDED HOUSING, BLUE COLOR
5.	ABS ASSEMBLY HOUSING, BLUE COLOR

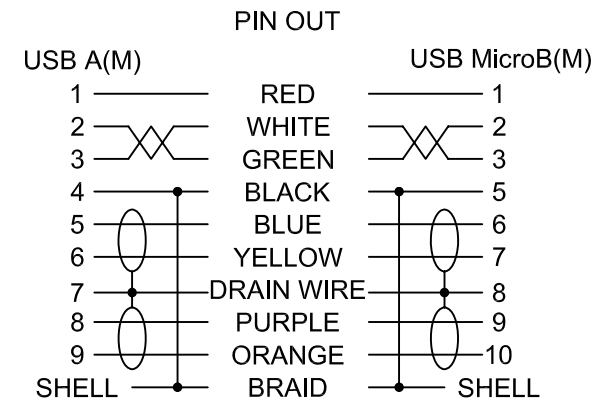

Jargy part no.	Client part no.	Approved	SCALE	UNIT
CBL-USPD302MB-XmLA			1 : 1	mm
Drawing Name		Drawn	Date	REV.
USB 3.0 A to Micro-B Cable M/M		<i>Kevin Hsu</i>	2016/06/03	1.0

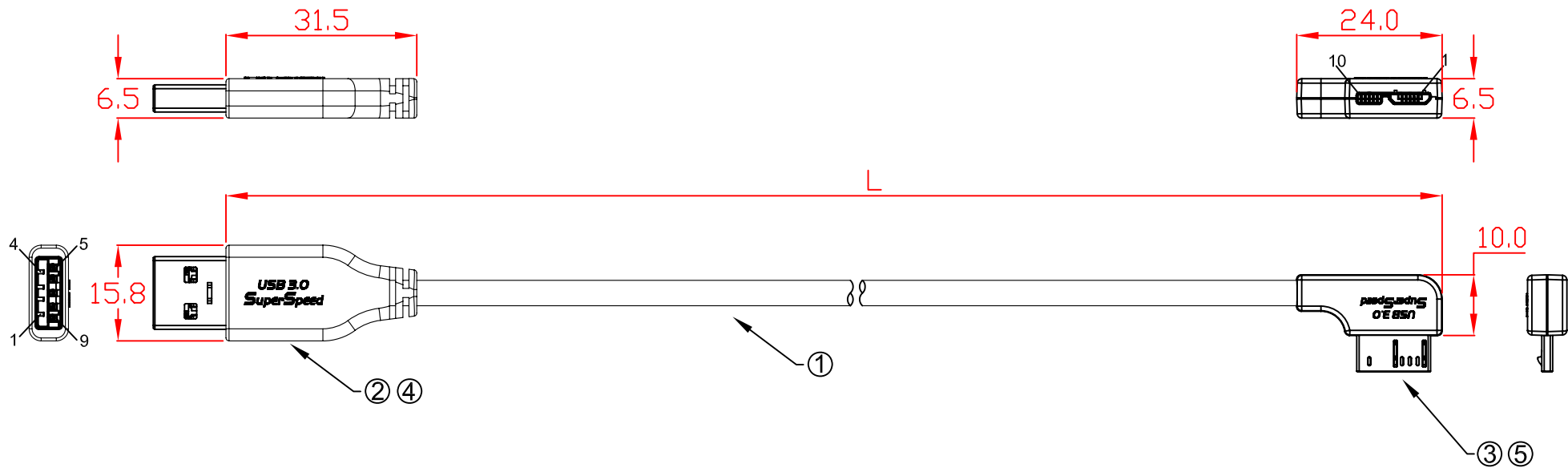

L:

- CBL-USPD302MB-0.5mRA 500mm±10mm
- CBL-USPD302MB-1mRA 1000mm±10mm
- CBL-USPD302MB-2mRA 2000mm±20mm
- CBL-USPD302MB-3mRA 3000mm±20mm

No	MATERIALS LIST:
1.	CABLE:UL2725 (32AWG*1PR+D+AM)x2C+32AWG*1PR+24AWG*1C+AM+B OD:4.2mm PVC JACKET COLOR:BLUE
2.	CONNECTOR:USB 3.0 A/M, 9P, BLUE INSULATOR SOLDER TYPE, NICKEL PLATED SHELL
3.	CONNECTOR:USB 3.0 MicroB/M, 10P, BLACK INSULATOR SOLDER TYPE, NICKEL PLATED SHELL
4.	PVC MOLDED HOUSING, BLUE COLOR
5.	ABS ASSEMBLY HOUSING, BLUE COLOR

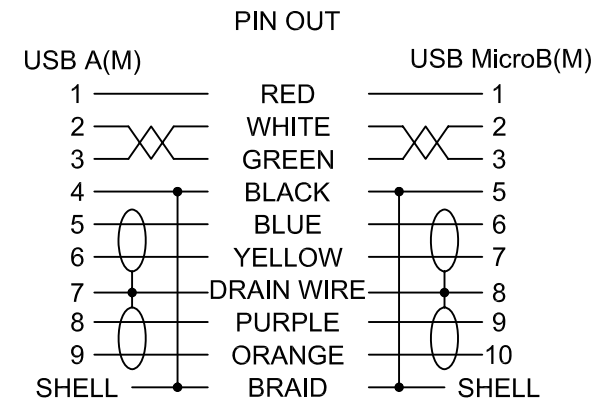

Jargy part no.	Client part no.	Approved	SCALE	UNIT
CBL-USPD302MB-XmRA			1 : 1	mm
Drawing Name		Drawn	Date	REV.
USB 3.0 A to Micro-B Cable M/M		<i>Kevin Hsu</i>	2016/06/03	1.0

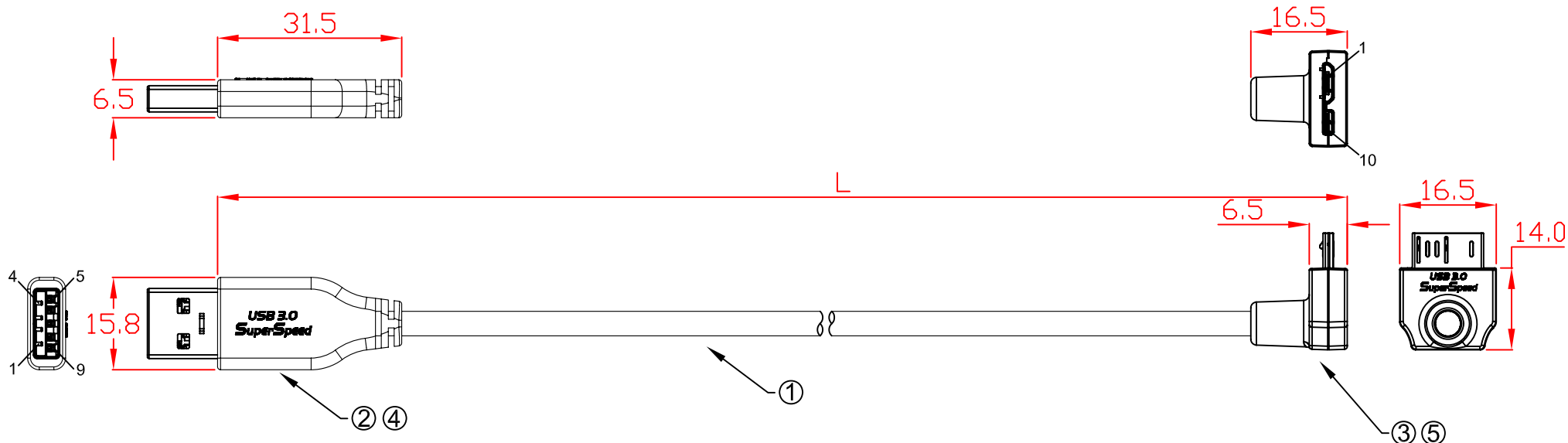

L:

- CBL-USPD302MB-0.5mUA 500mm±10mm
- CBL-USPD302MB-1mUA 1000mm±10mm
- CBL-USPD302MB-2mUA 2000mm±20mm
- CBL-USPD302MB-3mUA 3000mm±20mm

No	MATERIALS LIST:
1.	CABLE:UL2725 (32AWG*1PR+D+AM)x2C+32AWG*1PR+24AWG*1C+AM+B OD:4.2mm PVC JACKET COLOR:BLUE
2.	CONNECTOR:USB 3.0 A/M, 9P, BLUE INSULATOR SOLDER TYPE, NICKEL PLATED SHELL
3.	CONNECTOR:USB 3.0 MicroB/M, 10P, BLACK INSULATOR SOLDER TYPE, NICKEL PLATED SHELL
4.	PVC MOLDED HOUSING, BLUE COLOR
5.	ABS ASSEMBLY HOUSING, BLUE COLOR

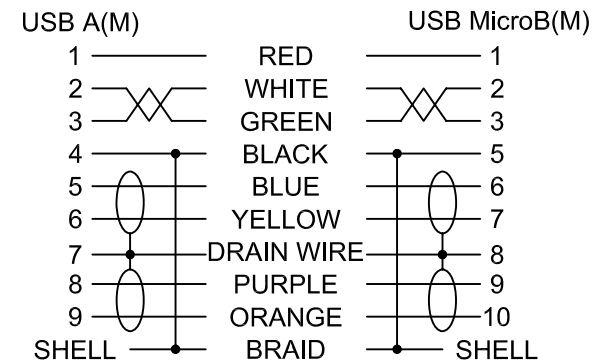

Jargy part no.	Client part no.	Approved	SCALE	UNIT
CBL-USPD302MB-XmUA			1 : 1	mm
Drawing Name		Drawn	Date	REV.
USB 3.0 A to Micro-B Cable M/M		<i>Kevin Hsu</i>	2016/06/03	1.0

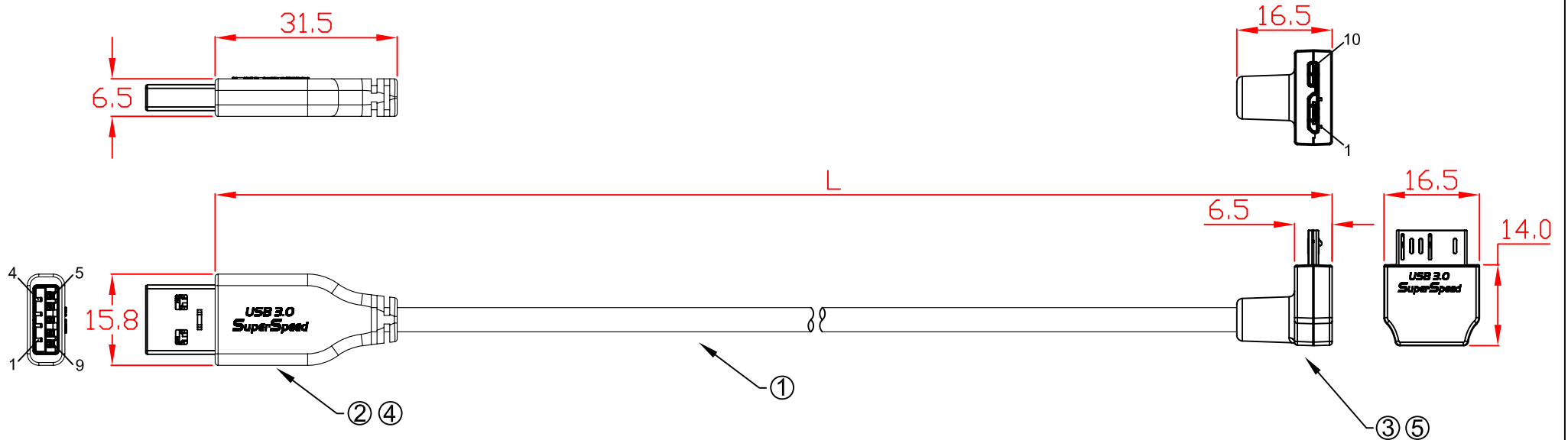

- L:
- CBL-USPD302MB-0.5mDA 500mm±10mm
  - CBL-USPD302MB-1mDA 1000mm±10mm
  - CBL-USPD302MB-2mDA 2000mm±20mm
  - CBL-USPD302MB-3mDA 3000mm±20mm

No	MATERIALS LIST:
1.	CABLE:UL2725 (32AWG*1PR+D+AM)x2C+32AWG*1PR+24AWG*1C+AM+B OD:4.2mm PVC JACKET COLOR:BLUE
2.	CONNECTOR:USB 3.0 A/M, 9P, BLUE INSULATOR SOLDER TYPE, NICKEL PLATED SHELL
3.	CONNECTOR:USB 3.0 MicroB/M, 10P, BLACK INSULATOR SOLDER TYPE, NICKEL PLATED SHELL
4.	PVC MOLDED HOUSING, BLUE COLOR
5.	ABS ASSEMBLY HOUSING, BLUE COLOR

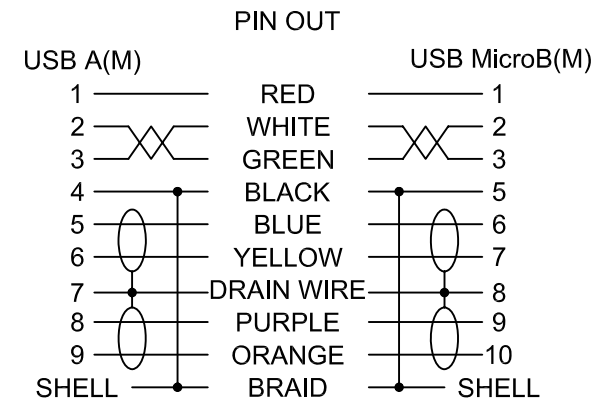

Jargy part no.	Client part no.	Approved	SCALE	UNIT
CBL-USPD302MB-XmDA			1 : 1	mm
Drawing Name		Drawn	Date	REV.
USB 3.0 A to Micro-B Cable M/M		<i>Kevin Hsu</i>	2016/06/03	1.0

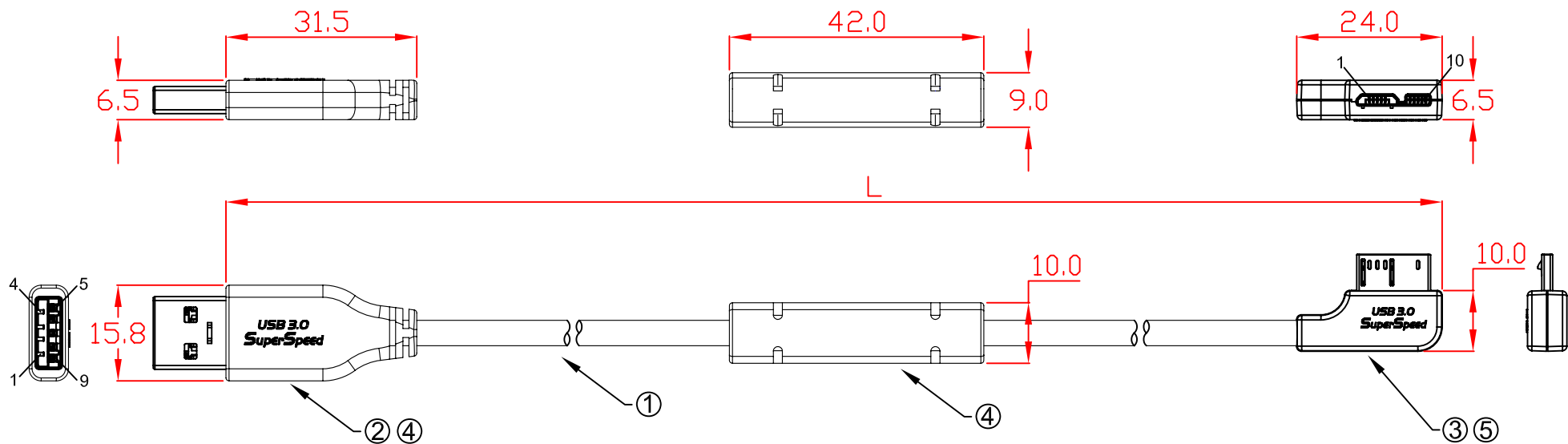

L:

- CBL-USD302MB-4mLA 4000mm±30mm
- CBL-USD302MB-5mLA 5000mm±30mm
- CBL-USD302MB-6mLA 6000mm±30mm
- CBL-USD302MB-7mLA 7000mm±30mm
- CBL-USD302MB-8mLA 8000mm±30mm

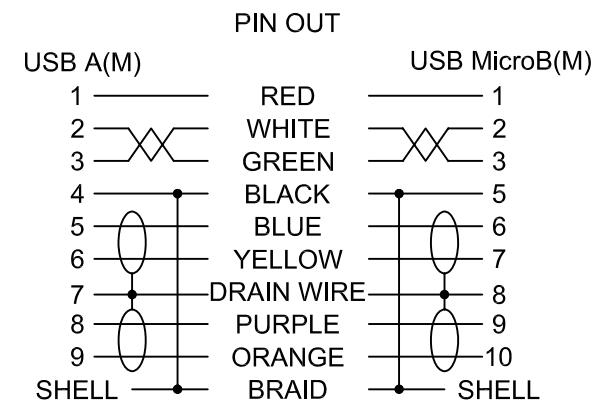

No	MATERIALS LIST:
1.	CABLE:UL2725 (32AWG*1PR+D+AM)x2C+32AWG*1PR+24AWG*1C+AM+B OD:4.2mm PVC JACKET COLOR:BLUE
2.	CONNECTOR:USB 3.0 A/M, 9P, BLUE INSULATOR SOLDER TYPE, NICKEL PLATED SHELL
3.	CONNECTOR:USB 3.0 MicroB/M, 10P, BLACK INSULATOR SOLDER TYPE, NICKEL PLATED SHELL
4.	PVC MOLDED HOUSING, BLUE COLOR
5.	ABS ASSEMBLY HOUSING, BLUE COLOR

Jargy part no.	Client part no.	Approved	SCALE	UNIT
CBL-USD302MB-XmLA			1 : 1	mm
Drawing Name		Drawn	Date	REV.
USB 3.0 A to Micro-B Cable M/M		<i>Kevin Hsu</i>	2016/06/03	1.0

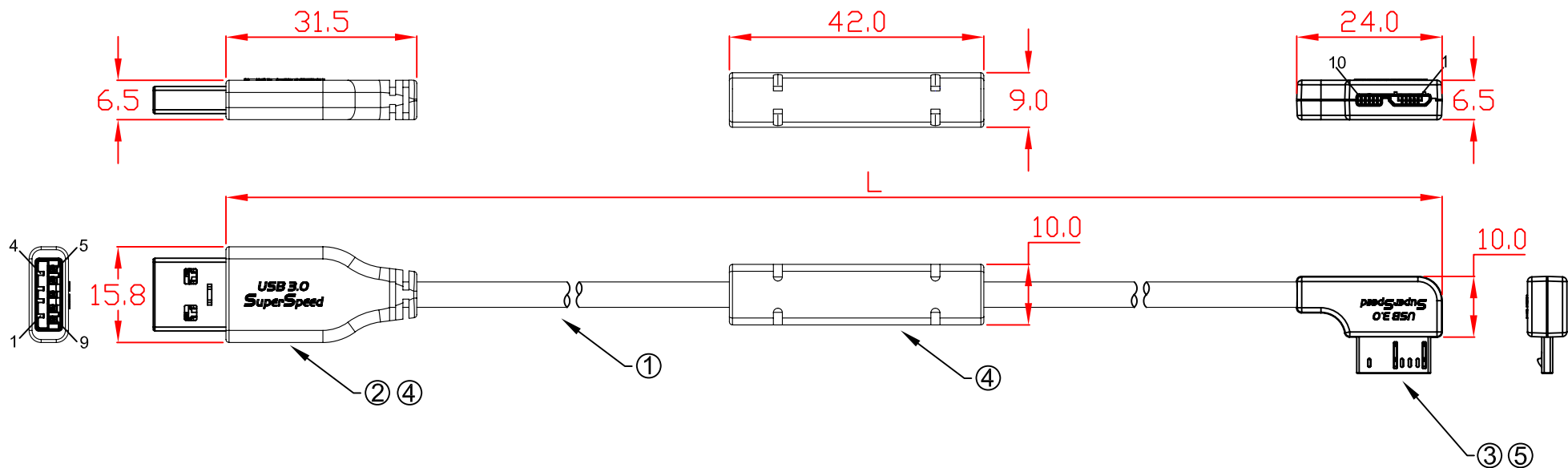

L:

CBL-USD302MB-4mRA	4000mm±30mm
CBL-USD302MB-5mRA	5000mm±30mm
CBL-USD302MB-6mRA	6000mm±30mm
CBL-USD302MB-7mRA	7000mm±30mm
CBL-USD302MB-8mRA	8000mm±30mm

No	MATERIALS LIST:
1.	CABLE:UL2725 (32AWG*1PR+D+AM)x2C+32AWG*1PR+24AWG*1C+AM+B OD:4.2mm PVC JACKET COLOR:BLUE
2.	CONNECTOR:USB 3.0 A/M, 9P, BLUE INSULATOR SOLDER TYPE, NICKEL PLATED SHELL
3.	CONNECTOR:USB 3.0 MicroB/M, 10P, BLACK INSULATOR SOLDER TYPE, NICKEL PLATED SHELL
4.	PVC MOLDED HOUSING, BLUE COLOR
5.	ABS ASSEMBLY HOUSING, BLUE COLOR

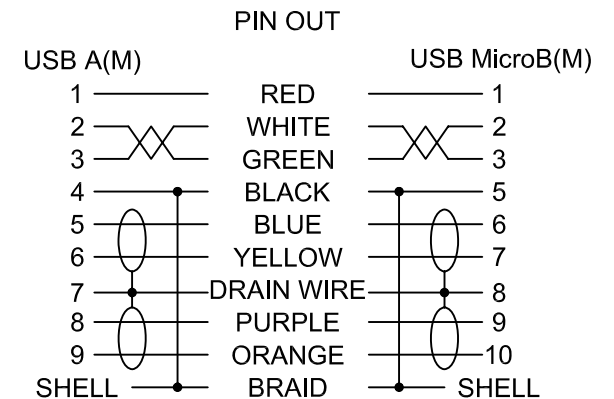

Jargy part no.	Client part no.	Approved	SCALE	UNIT
CBL-USD302MB-XmRA			1 : 1	mm
Drawing Name		Drawn	Date	REV.
USB 3.0 A to Micro-B Cable M/M		<i>Kevin Hsu</i>	2016/06/03	1.0

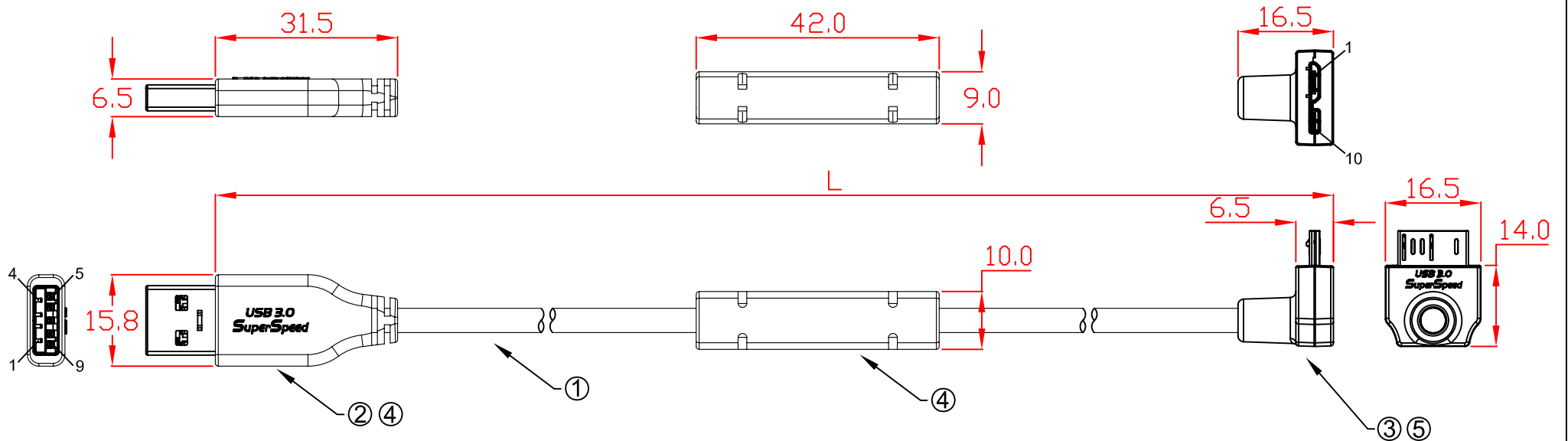

L:

- CBL-USD302MB-4mUA 4000mm±30mm
- CBL-USD302MB-5mUA 5000mm±30mm
- CBL-USD302MB-6mUA 6000mm±30mm
- CBL-USD302MB-7mUA 7000mm±30mm
- CBL-USD302MB-8mUA 8000mm±30mm

No	MATERIALS LIST:
1.	CABLE:UL2725 (32AWG*1PR+D+AM)x2C+32AWG*1PR+24AWG*1C+AM+B OD:4.2mm PVC JACKET COLOR:BLUE
2.	CONNECTOR:USB 3.0 A/M, 9P, BLUE INSULATOR SOLDER TYPE, NICKEL PLATED SHELL
3.	CONNECTOR:USB 3.0 MicroB/M, 10P, BLACK INSULATOR SOLDER TYPE, NICKEL PLATED SHELL
4.	PVC MOLDED HOUSING, BLUE COLOR
5.	ABS ASSEMBLY HOUSING, BLUE COLOR

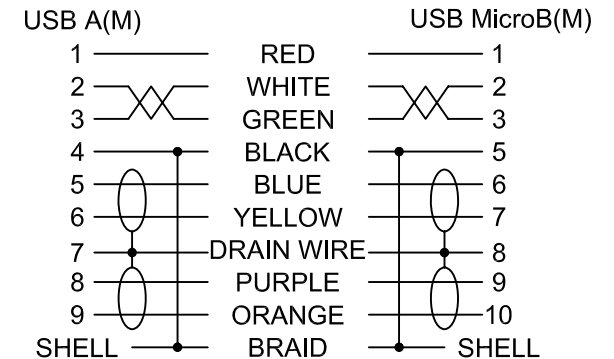

Jargy part no.	Client part no.	Approved	SCALE	UNIT
CBL-USD302MB-XmUA			1 : 1	mm
Drawing Name		Drawn	Date	REV.
USB 3.0 A to Micro-B Cable M/M		<i>Kevin Hsu</i>	2016/06/03	1.0

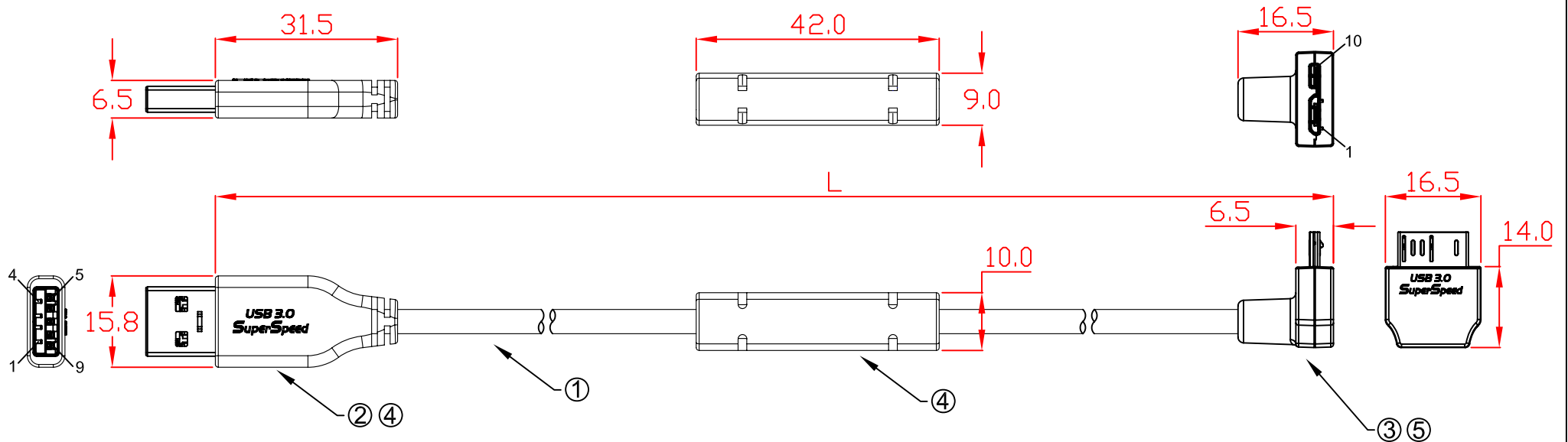

- L:
- CBL-USD302MB-4mDA 4000mm±30mm
  - CBL-USD302MB-5mDA 5000mm±30mm
  - CBL-USD302MB-6mDA 6000mm±30mm
  - CBL-USD302MB-7mDA 7000mm±30mm
  - CBL-USD302MB-8mDA 8000mm±30mm

No	MATERIALS LIST:
1.	CABLE:UL2725 (32AWG*1PR+D+AM)x2C+32AWG*1PR+24AWG*1C+AM+B OD:4.2mm PVC JACKET COLOR:BLUE
2.	CONNECTOR:USB 3.0 A/M, 9P, BLUE INSULATOR SOLDER TYPE, NICKEL PLATED SHELL
3.	CONNECTOR:USB 3.0 MicroB/M, 10P, BLACK INSULATOR SOLDER TYPE, NICKEL PLATED SHELL
4.	PVC MOLDED HOUSING, BLUE COLOR
5.	ABS ASSEMBLY HOUSING, BLUE COLOR

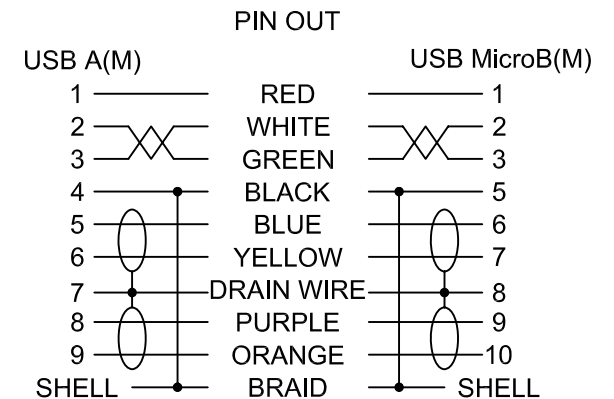

Jargy part no.	Client part no.	Approved	SCALE	UNIT
CBL-USD302MB-XmDA			1 : 1	mm
Drawing Name		Drawn	Date	REV.
USB 3.0 A to Micro-B Cable M/M		<i>Kevin Hsu</i>	2016/06/03	1.0



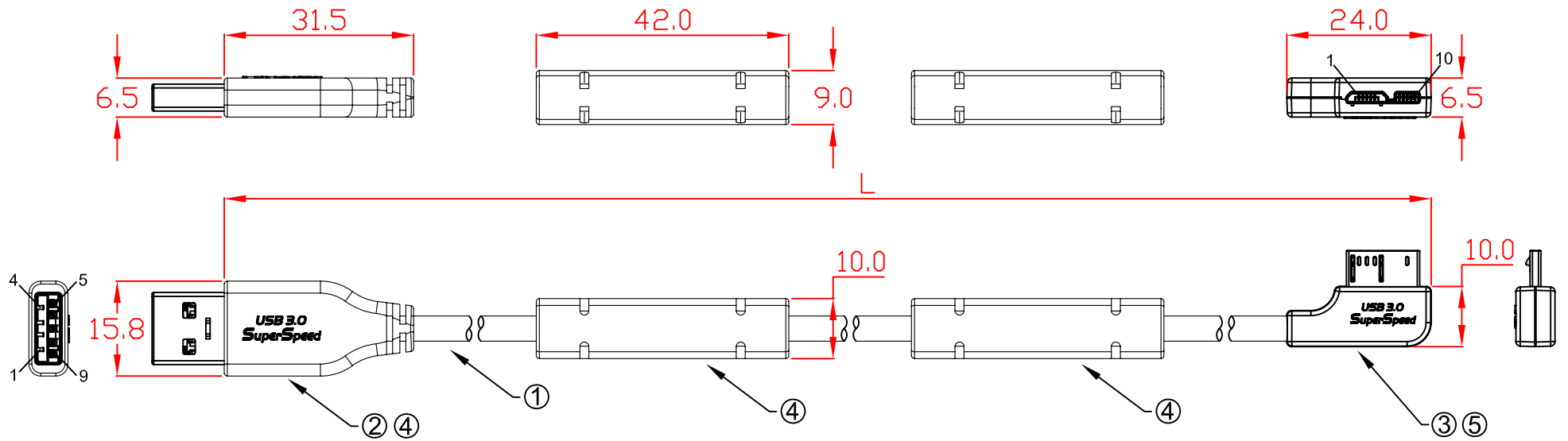

- L:
- CBL-USD302MB-9mLA 9000mm±50mm
  - CBL-USD302MB-10mLA 10000mm±50mm
  - CBL-USD302MB-11mLA 11000mm±50mm
  - CBL-USD302MB-12mLA 12000mm±50mm

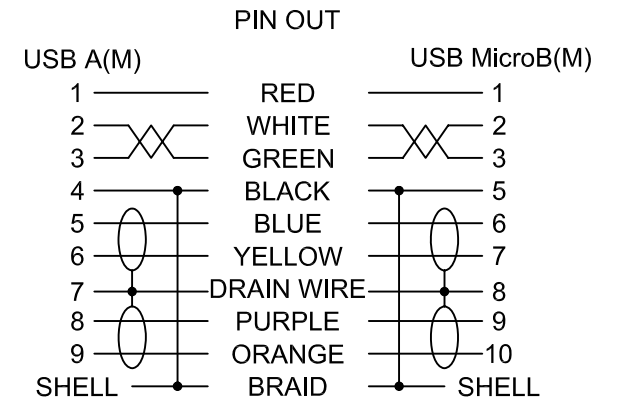

No	MATERIALS LIST:
1.	CABLE:UL2725 (32AWG*1PR+D+AM)x2C+32AWG*1PR+24AWG*1C+AM+B OD:4.2mm PVC JACKET COLOR:BLUE
2.	CONNECTOR:USB 3.0 A/M, 9P, BLUE INSULATOR SOLDER TYPE, NICKEL PLATED SHELL
3.	CONNECTOR:USB 3.0 MicroB/M, 10P, BLACK INSULATOR SOLDER TYPE, NICKEL PLATED SHELL
4.	PVC MOLDED HOUSING, BLUE COLOR
5.	ABS ASSEMBLY HOUSING, BLUE COLOR

Jargy part no.	Client part no.	Approved	SCALE	UNIT
CBL-USD302MB-XmLA			1 : 1	mm
Drawing Name		Drawn	Date	REV.
USB 3.0 A to Micro-B Cable M/M		<i>Kevin Hsu</i>	2016/06/03	1.0

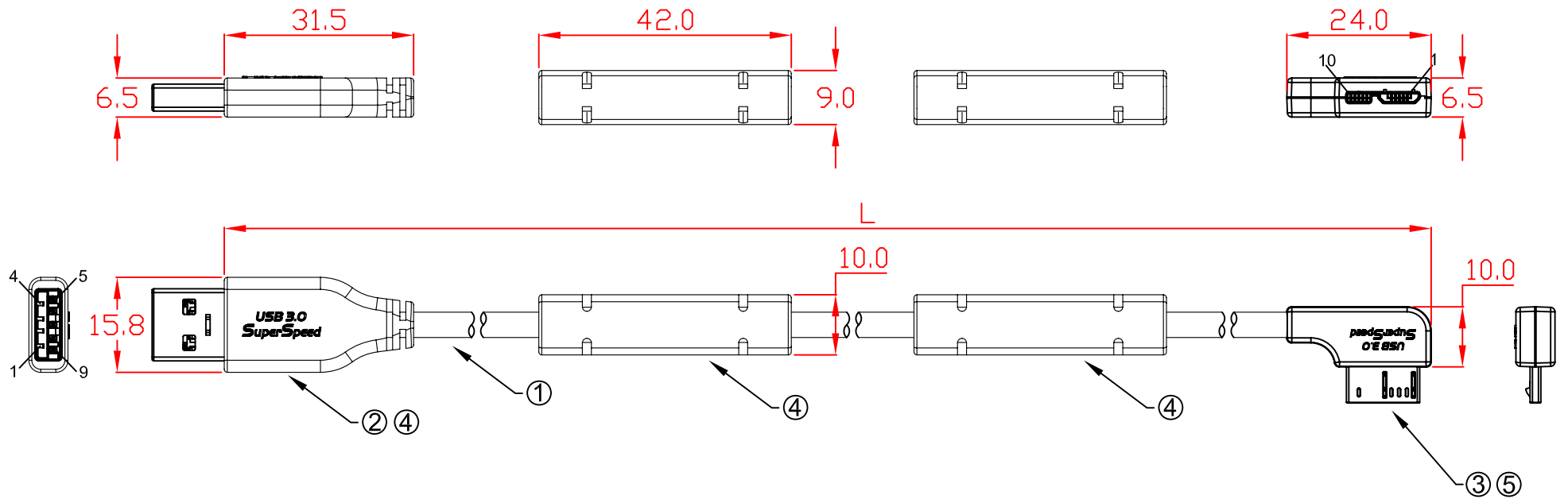

L:

CBL-USD302MB-9mRA	9000mm±50mm
CBL-USD302MB-10mRA	10000mm±50mm
CBL-USD302MB-11mRA	11000mm±50mm
CBL-USD302MB-12mRA	12000mm±50mm

No	MATERIALS LIST:
1.	CABLE:UL2725 (32AWG*1PR+D+AM)x2C+32AWG*1PR+24AWG*1C+AM+B OD:4.2mm PVC JACKET COLOR:BLUE
2.	CONNECTOR:USB 3.0 A/M, 9P, BLUE INSULATOR SOLDER TYPE, NICKEL PLATED SHELL
3.	CONNECTOR:USB 3.0 MicroB/M, 10P, BLACK INSULATOR SOLDER TYPE, NICKEL PLATED SHELL
4.	PVC MOLDED HOUSING, BLUE COLOR
5.	ABS ASSEMBLY HOUSING, BLUE COLOR

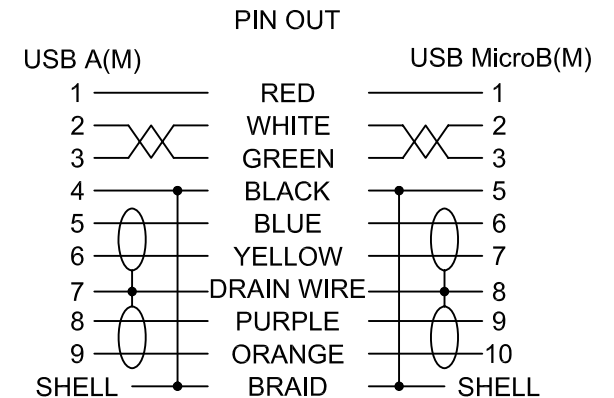

Jargy part no.	Client part no.	Approved	SCALE	UNIT
CBL-USD302MB-XmRA			1 : 1	mm
Drawing Name		Drawn	Date	REV.
USB 3.0 A to Micro-B Cable M/M		<i>Kevin Hsu</i>	2016/06/03	1.0

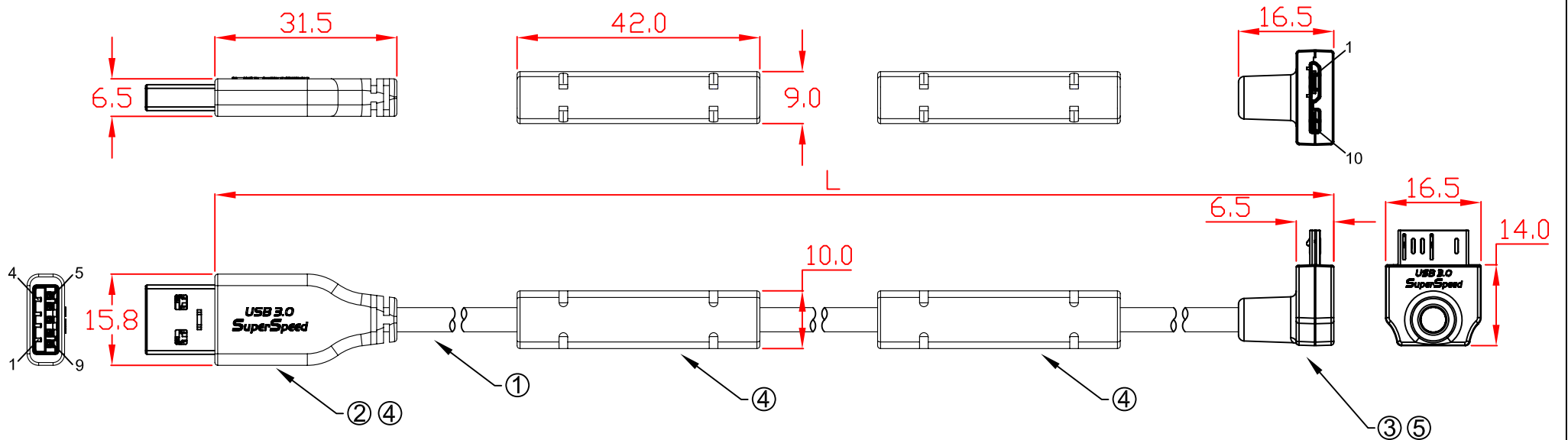

- L:
- CBL-USD302MB-9mUA 9000mm±50mm
  - CBL-USD302MB-10mUA 10000mm±50mm
  - CBL-USD302MB-11mUA 11000mm±50mm
  - CBL-USD302MB-12mUA 12000mm±50mm

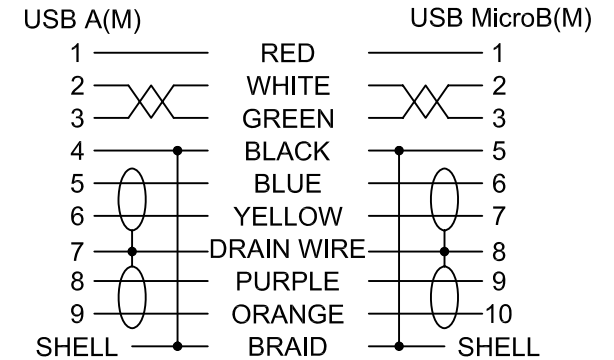

No	MATERIALS LIST:
1.	CABLE:UL2725 (32AWG*1PR+D+AM)x2C+32AWG*1PR+24AWG*1C+AM+B OD:4.2mm PVC JACKET COLOR:BLUE
2.	CONNECTOR:USB 3.0 A/M, 9P, BLUE INSULATOR SOLDER TYPE, NICKEL PLATED SHELL
3.	CONNECTOR:USB 3.0 MicroB/M, 10P, BLACK INSULATOR SOLDER TYPE, NICKEL PLATED SHELL
4.	PVC MOLDED HOUSING, BLUE COLOR
5.	ABS ASSEMBLY HOUSING, BLUE COLOR

Jargy part no.	Client part no.	Approved	SCALE	UNIT
CBL-USD302MB-XmUA			1 : 1	mm
Drawing Name		Drawn	Date	REV.
USB 3.0 A to Micro-B Cable M/M		<i>Kevin Hsu</i>	2016/06/03	1.0

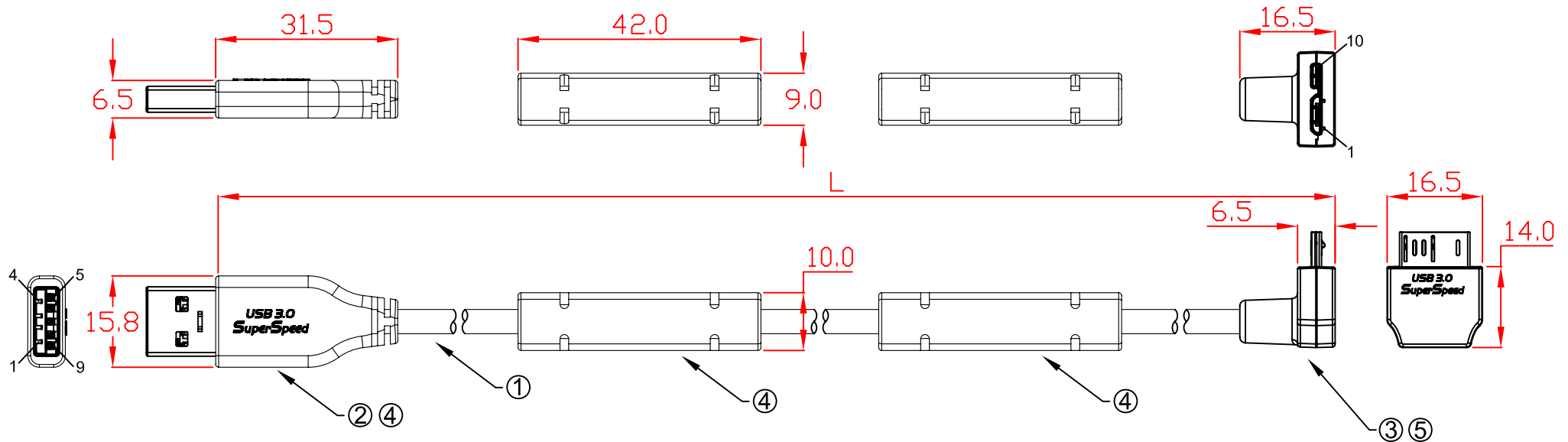

L:

CBL-USD302MB-9mDA	9000mm±50mm
CBL-USD302MB-10mDA	10000mm±50mm
CBL-USD302MB-11mDA	11000mm±50mm
CBL-USD302MB-12mDA	12000mm±50mm

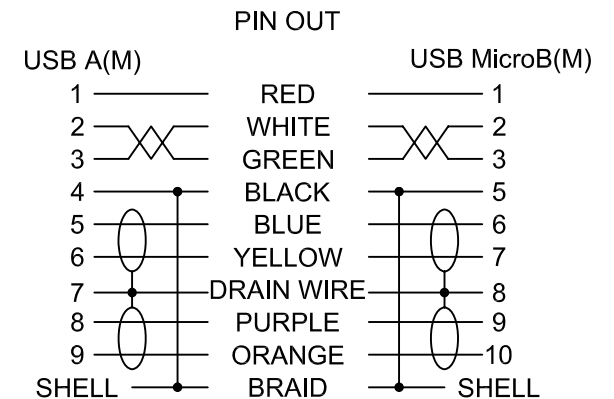

No	MATERIALS LIST:
1.	CABLE:UL2725 (32AWG*1PR+D+AM)x2C+32AWG*1PR+24AWG*1C+AM+B OD:4.2mm PVC JACKET COLOR:BLUE
2.	CONNECTOR:USB 3.0 A/M, 9P, BLUE INSULATOR SOLDER TYPE, NICKEL PLATED SHELL
3.	CONNECTOR:USB 3.0 MicroB/M, 10P, BLACK INSULATOR SOLDER TYPE, NICKEL PLATED SHELL
4.	PVC MOLDED HOUSING, BLUE COLOR
5.	ABS ASSEMBLY HOUSING, BLUE COLOR

Jargy part no.	Client part no.	Approved	SCALE	UNIT
CBL-USD302MB-XmDA			1 : 1	mm
Drawing Name		Drawn	Date	REV.
USB 3.0 A to Micro-B Cable M/M		<i>Kevin Hsu</i>	2016/06/03	1.0

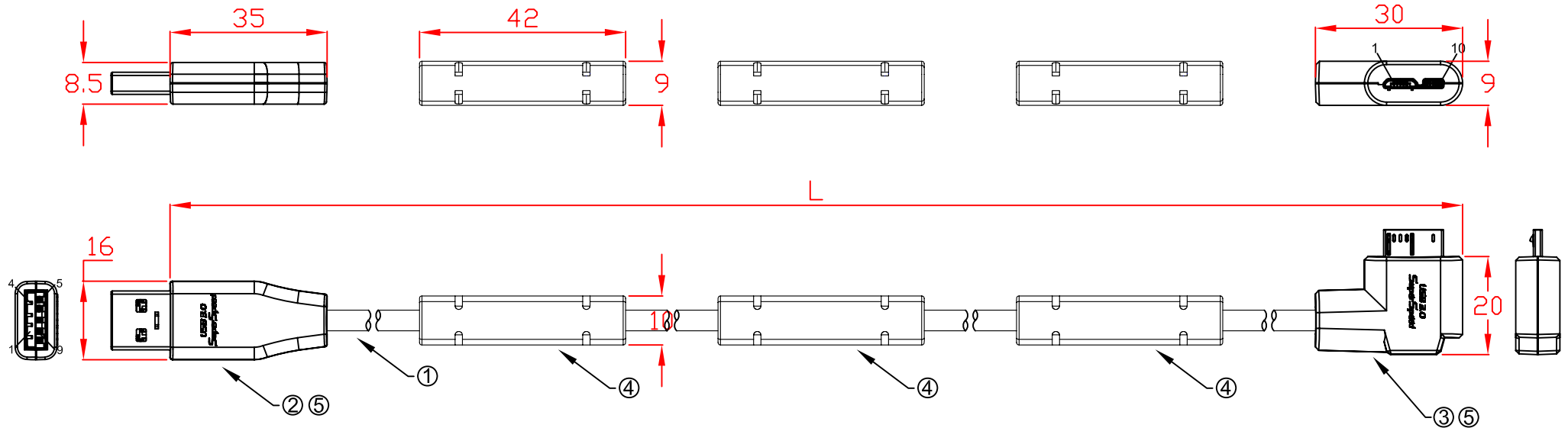

L:

- CBL-USD302MB-13mLA 13000mm±50mm
- CBL-USD302MB-14mLA 14000mm±50mm
- CBL-USD302MB-15mLA 15000mm±50mm
- CBL-USD302MB-16mLA 16000mm±50mm

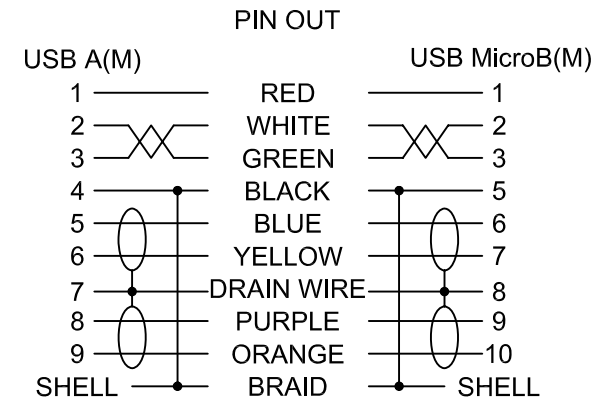

No	MATERIALS LIST:
1.	CABLE:UL2725 (32AWG*1PR+D+AM)x2C+32AWG*1PR+24AWG*1C+AM+B OD:4.2mm PVC JACKET COLOR:BLUE
2.	CONNECTOR:USB 3.0 A/M, 9P, BLUE INSULATOR SOLDER TYPE, NICKEL PLATED SHELL
3.	CONNECTOR:USB 3.0 MicroB/M, 10P, BLACK INSULATOR SOLDER TYPE, NICKEL PLATED SHELL
4.	PVC MOLDED HOUSING, BLUE COLOR
5.	ABS ASSEMBLY HOUSING, BLUE COLOR

Jargy part no.	Client part no.	Approved	SCALE	UNIT
CBL-USD302MB-XmLA			1 : 1	mm
Drawing Name		Drawn	Date	REV.
USB 3.0 A to Micro-B Cable M/M		<i>Kevin Hsu</i>	2016/06/04	1.0

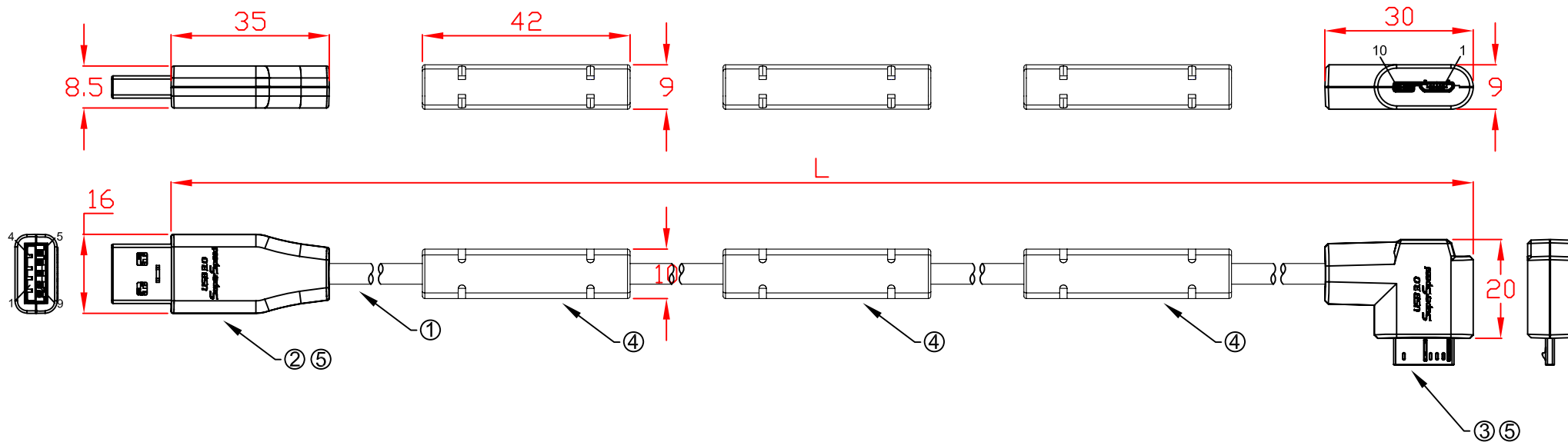

L:

CBL-USD302MB-13mRA	13000mm±50mm
CBL-USD302MB-14mRA	14000mm±50mm
CBL-USD302MB-15mRA	15000mm±50mm
CBL-USD302MB-16mRA	16000mm±50mm

No	MATERIALS LIST:
1.	CABLE:UL2725 (32AWG*1PR+D+AM)x2C+32AWG*1PR+24AWG*1C+AM+B OD:4.2mm PVC JACKET COLOR:BLUE
2.	CONNECTOR:USB 3.0 A/M, 9P, BLUE INSULATOR SOLDER TYPE, NICKEL PLATED SHELL
3.	CONNECTOR:USB 3.0 MicroB/M, 10P, BLACK INSULATOR SOLDER TYPE, NICKEL PLATED SHELL
4.	PVC MOLDED HOUSING, BLUE COLOR
5.	ABS ASSEMBLY HOUSING, BLUE COLOR

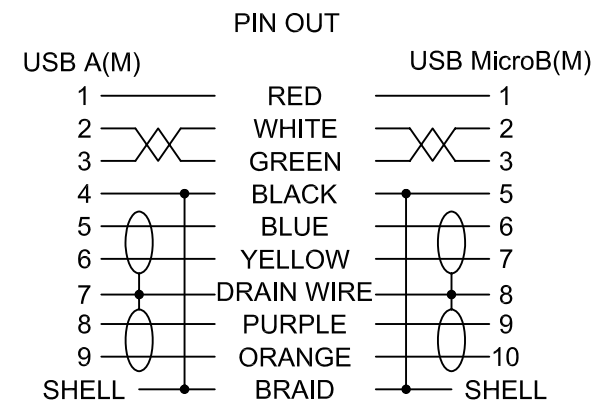

Jargy part no.	Client part no.	Approved	SCALE	UNIT
CBL-USD302MB-XmRA			1 : 1	mm
Drawing Name		Drawn	Date	REV.
USB 3.0 A to Micro-B Cable M/M		<i>Kevin Hsu</i>	2016/06/04	1.0

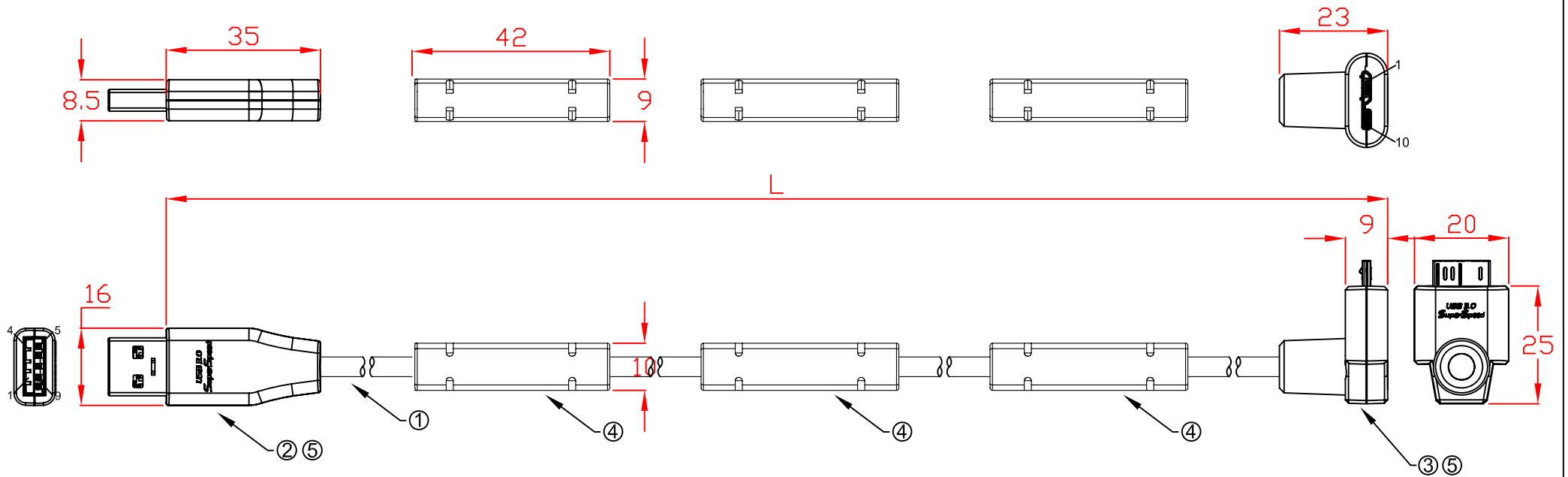

L:

CBL-USD302MB-13mUA	13000mm±50mm
CBL-USD302MB-14mUA	14000mm±50mm
CBL-USD302MB-15mUA	15000mm±50mm
CBL-USD302MB-16mUA	16000mm±50mm

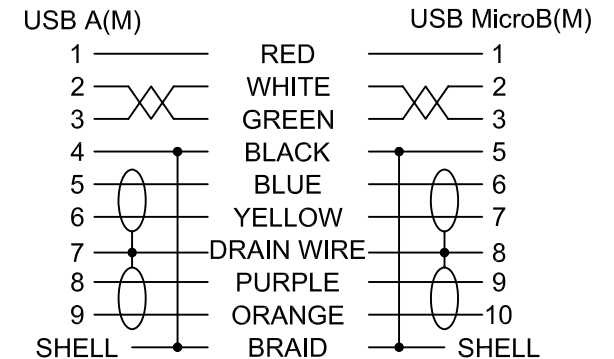

No	MATERIALS LIST:
1.	CABLE:UL2725 (32AWG*1PR+D+AM)x2C+32AWG*1PR+24AWG*1C+AM+B OD:4.2mm PVC JACKET COLOR:BLUE
2.	CONNECTOR:USB 3.0 A/M, 9P, BLUE INSULATOR SOLDER TYPE, NICKEL PLATED SHELL
3.	CONNECTOR:USB 3.0 MicroB/M, 10P, BLACK INSULATOR SOLDER TYPE, NICKEL PLATED SHELL
4.	PVC MOLDED HOUSING, BLUE COLOR
5.	ABS ASSEMBLY HOUSING, BLUE COLOR

Jargy part no.	Client part no.	Approved	SCALE	UNIT
CBL-USD302MB-XmUA			1 : 1	mm
Drawing Name		Drawn	Date	REV.
USB 3.0 A to Micro-B Cable M/M		<i>Kevin Hsu</i>	2016/06/04	1.0

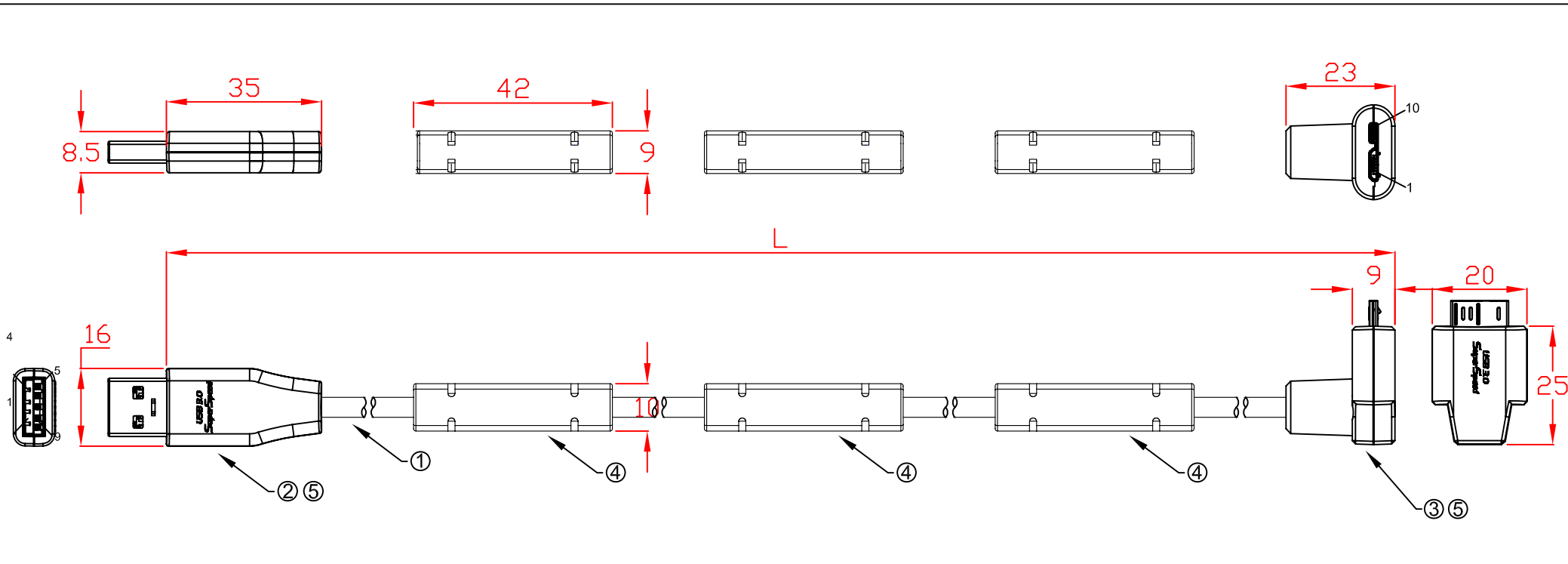

- L:
- CBL-USD302MB-13mDA 13000mm±50mm
  - CBL-USD302MB-14mDA 14000mm±50mm
  - CBL-USD302MB-15mDA 15000mm±50mm
  - CBL-USD302MB-16mDA 16000mm±50mm

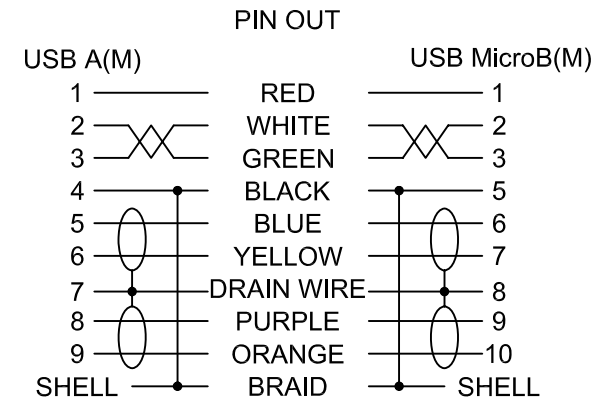

No	MATERIALS LIST:
1.	CABLE:UL2725 (32AWG*1PR+D+AM)x2C+32AWG*1PR+24AWG*1C+AM+B OD:4.2mm PVC JACKET COLOR:BLUE
2.	CONNECTOR:USB 3.0 A/M, 9P, BLUE INSULATOR SOLDER TYPE, NICKEL PLATED SHELL
3.	CONNECTOR:USB 3.0 MicroB/M, 10P, BLACK INSULATOR SOLDER TYPE, NICKEL PLATED SHELL
4.	PVC MOLDED HOUSING, BLUE COLOR
5.	ABS ASSEMBLY HOUSING, BLUE COLOR

Jargy part no.	Client part no.	Approved	SCALE	UNIT
CBL-USD302MB-XmDA			1 : 1	mm
Drawing Name		Drawn	Date	REV.
USB 3.0 A to Micro-B Cable M/M		<i>Kevin Hsu</i>	2016/06/04	1.0



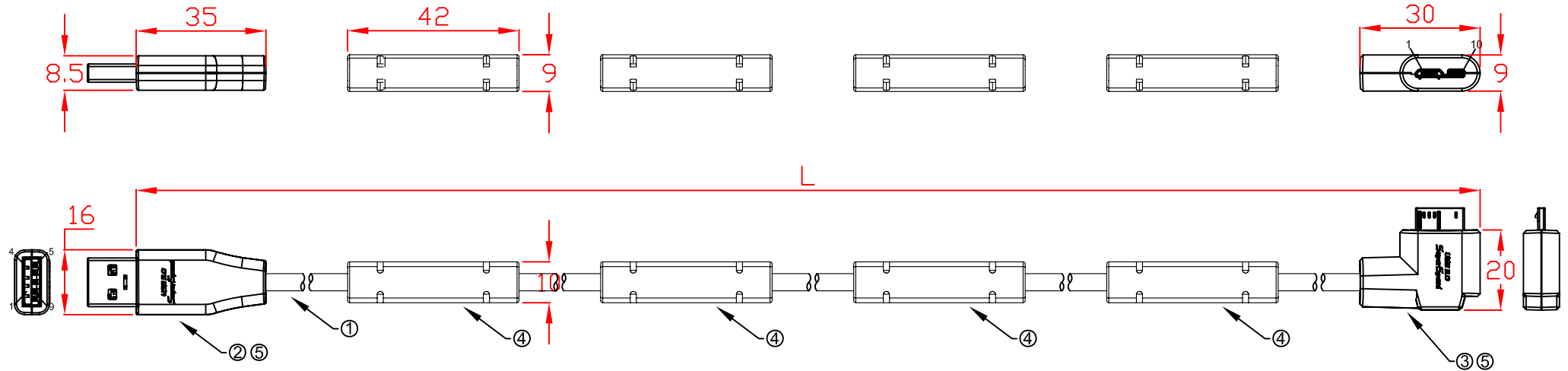

- L:
- CBL-USD302MB-17mLA 17000mm±50mm
  - CBL-USD302MB-18mLA 18000mm±50mm
  - CBL-USD302MB-19mLA 19000mm±50mm
  - CBL-USD302MB-20mLA 20000mm±50mm

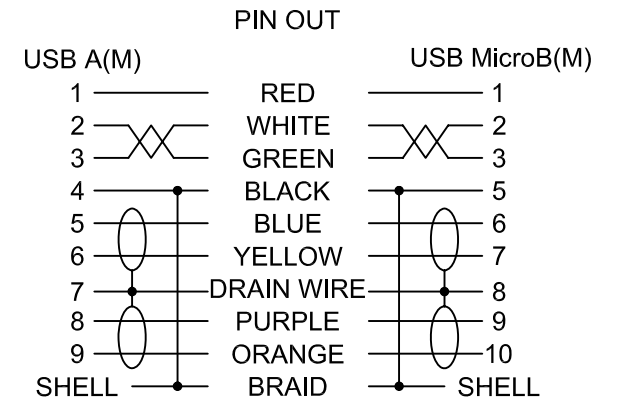

No	MATERIALS LIST:
1.	CABLE:UL2725 (32AWG*1PR+D+AM)x2C+32AWG*1PR+24AWG*1C+AM+B OD:4.2mm PVC JACKET COLOR:BLUE
2.	CONNECTOR:USB 3.0 A/M, 9P, BLUE INSULATOR SOLDER TYPE, NICKEL PLATED SHELL
3.	CONNECTOR:USB 3.0 MicroB/M, 10P, BLACK INSULATOR SOLDER TYPE, NICKEL PLATED SHELL
4.	PVC MOLDED HOUSING, BLUE COLOR
5.	ABS ASSEMBLY HOUSING, BLUE COLOR

Jargy part no.	Client part no.	Approved	SCALE	UNIT
CBL-USD302MB-XmLA			1 : 1	mm
Drawing Name		Drawn	Date	REV.
USB 3.0 A to Micro-B Cable M/M		<i>Kevin Hsu</i>	2016/06/04	1.0

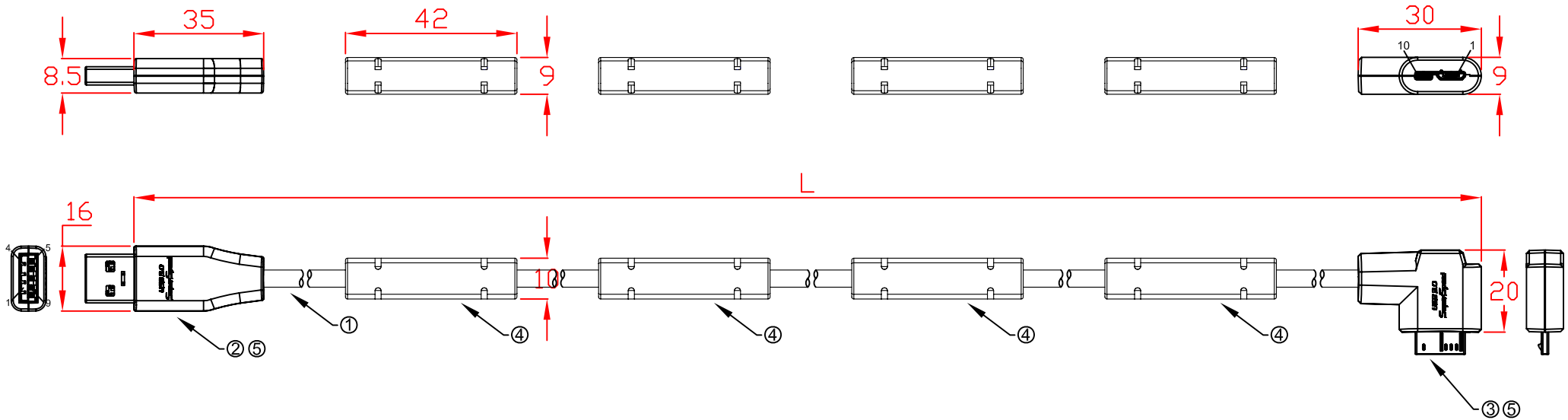

L:

- CBL-USD302MB-17mRA 17000mm±50mm
- CBL-USD302MB-18mRA 18000mm±50mm
- CBL-USD302MB-19mRA 19000mm±50mm
- CBL-USD302MB-20mRA 20000mm±50mm

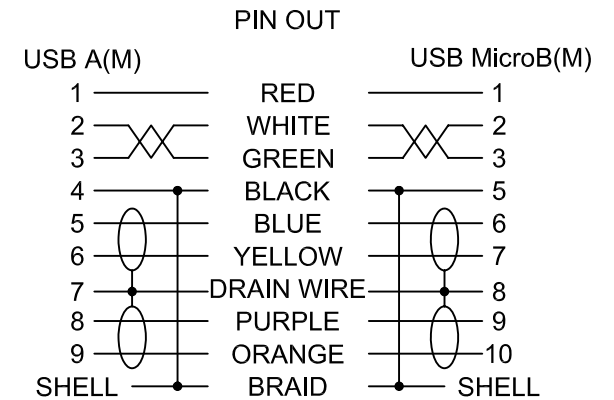

No	MATERIALS LIST:
1.	CABLE:UL2725 (32AWG*1PR+D+AM)x2C+32AWG*1PR+24AWG*1C+AM+B OD:4.2mm PVC JACKET COLOR:BLUE
2.	CONNECTOR:USB 3.0 A/M, 9P, BLUE INSULATOR SOLDER TYPE, NICKEL PLATED SHELL
3.	CONNECTOR:USB 3.0 MicroB/M, 10P, BLACK INSULATOR SOLDER TYPE, NICKEL PLATED SHELL
4.	PVC MOLDED HOUSING, BLUE COLOR
5.	ABS ASSEMBLY HOUSING, BLUE COLOR

Jargy part no.	Client part no.	Approved	SCALE	UNIT
CBL-USD302MB-XmRA			1 : 1	mm
Drawing Name		Drawn	Date	REV.
USB 3.0 A to Micro-B Cable M/M		<i>Kevin Hsu</i>	2016/06/04	1.0

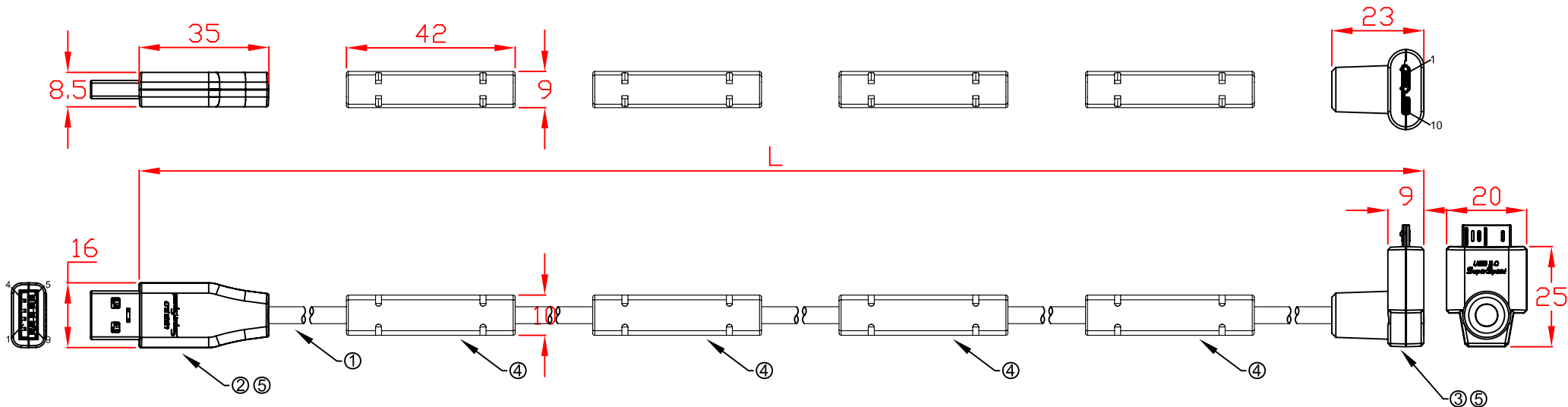

L:

- CBL-USD302MB-17mUA 17000mm±50mm
- CBL-USD302MB-18mUA 18000mm±50mm
- CBL-USD302MB-19mUA 19000mm±50mm
- CBL-USD302MB-20mUA 20000mm±50mm

USB A(M)

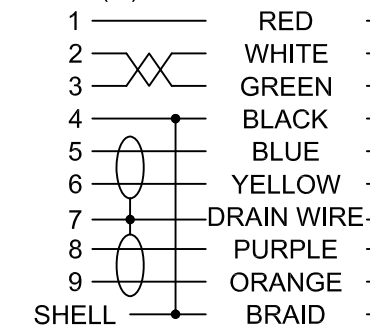

USB MicroB(M)

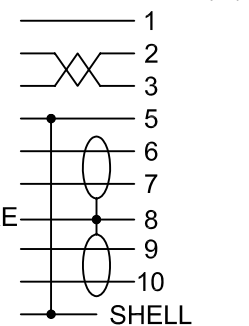

No	MATERIALS LIST:
1.	CABLE:UL2725 (32AWG*1PR+D+AM)x2C+32AWG*1PR+24AWG*1C+AM+B OD:4.2mm PVC JACKET COLOR:BLUE
2.	CONNECTOR:USB 3.0 A/M, 9P, BLUE INSULATOR SOLDER TYPE, NICKEL PLATED SHELL
3.	CONNECTOR:USB 3.0 MicroB/M, 10P, BLACK INSULATOR SOLDER TYPE, NICKEL PLATED SHELL
4.	PVC MOLDED HOUSING, BLUE COLOR
5.	ABS ASSEMBLY HOUSING, BLUE COLOR

Jargy part no.	Client part no.	Approved	SCALE	UNIT
CBL-USD302MB-XmUA			1 : 1	mm
Drawing Name		Drawn	Date	REV.
USB 3.0 A to Micro-B Cable M/M		<i>Kevin Hsu</i>	2016/06/04	1.0

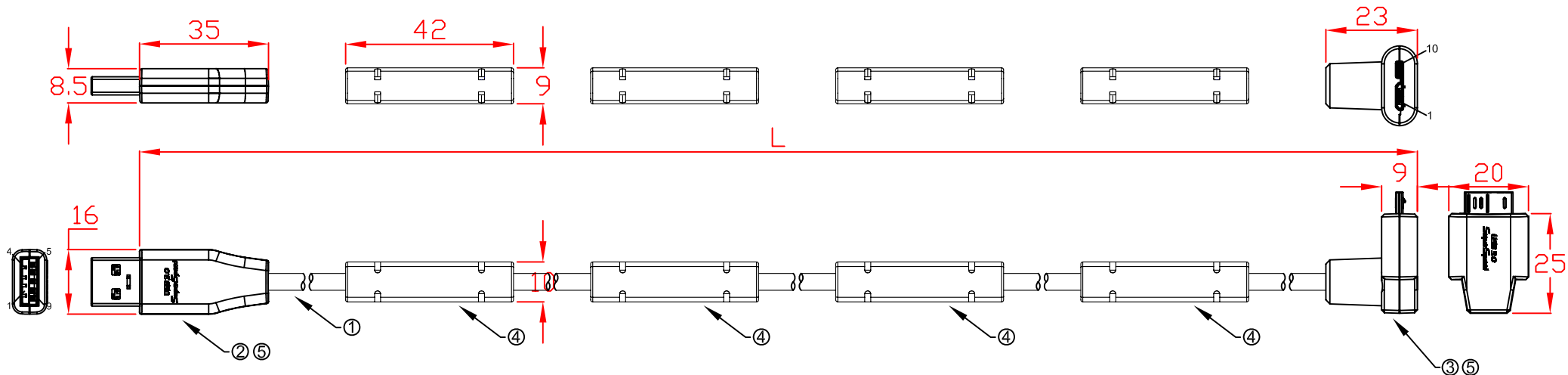

L:

CBL-USD302MB-17mDA	17000mm±50mm
CBL-USD302MB-18mDA	18000mm±50mm
CBL-USD302MB-19mDA	19000mm±50mm
CBL-USD302MB-20mDA	20000mm±50mm

No MATERIALS LIST:

1.	CABLE:UL2725 (32AWG*1PR+D+AM)x2C+32AWG*1PR+24AWG*1C+AM+B OD:4.2mm PVC JACKET COLOR:BLUE
2.	CONNECTOR:USB 3.0 A/M, 9P, BLUE INSULATOR SOLDER TYPE, NICKEL PLATED SHELL
3.	CONNECTOR:USB 3.0 MicroB/M, 10P, BLACK INSULATOR SOLDER TYPE, NICKEL PLATED SHELL
4.	PVC MOLDED HOUSING, BLUE COLOR
5.	ABS ASSEMBLY HOUSING, BLUE COLOR

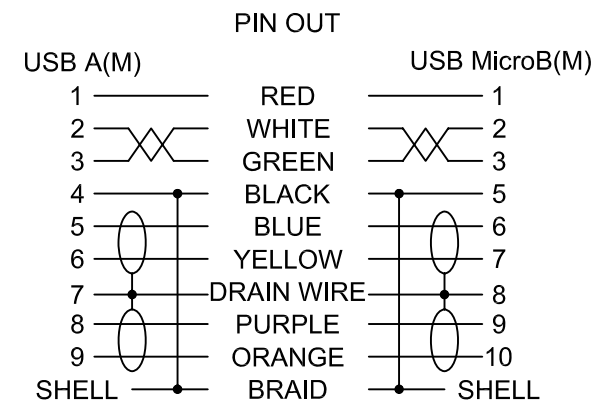

Jargy part no.	Client part no.	Approved	SCALE	UNIT
CBL-USD302MB-XmDA			1 : 1	mm
Drawing Name		Drawn	Date	REV.
USB 3.0 A to Micro-B Cable M/M		<i>Kevin Hsu</i>	2016/06/04	1.0